



TECTON IP64 / IP54

AN EFFICIENT LIGHTING SYSTEM. EFFECTIVE AGAINST DUST AND SPLASH WATER.



Volvo Trucks, Ghent | BE



GRAF Nutzfahrzeuge, Hunzenschwil | CH



Whether in joiner's workshops or in cold warehouses: The TECTON IP64/IP54 system is reliably protected against the ingress of foreign bodies and splash water. Optimal for use in dusty or humid environments.

TECTON IP64/IP54

IP – two letters, one promise: TECTON IP64/IP54 makes the advantages of the tried-and-tested continuous-row lighting system available for demanding industrial environments. The dust-proof and splashproof TECTON IP64/IP54 variant can be used wherever metal, wood or paper is processed, food is kept cool, or car parks are lit. Quick, tool-free installation. 100 % flexible – can be fitted with general lighting, safety lighting and lighting management. With Zumtobel Services if required: from project design to installation and maintenance, we offer support throughout the entire life cycle of a lighting solution.





NO CHANCE FOR DUST AND SPLASH WATER

Stays sealed: the sophisticated sealing concept offers effective protection against dust and splash water for the entire TECTON IP64/IP54 system. All critical joints and connections are equipped with sealing components made of carefully selected materials that are resistant to chemical influences and mechanical stresses. However, the extra degree of protection never compromises the convenience of installation. Even in the IP-protected version, TECTON is still easy to fit with components and can be installed without tools.

1

At the end of the tracks, a closed **end cap** ensures that cables are protected against water and dust when inserted. To achieve this, up to four "push-out" membranes, which provide an excellent seal for the supply lines, can be pushed through. In the end caps, integrated felt seals prevent unwanted dirt particles getting in. They also ensure the necessary pressure and moisture balance inside the track.

2

In the area of the coupling joints between two trunkings, a **gasket** prevents dirt or water getting inside the track.

3

The **end caps** of the continuous-row luminaires and modules are made of resistant plastic that is firmly bonded to a soft sealing lip. The elastic, adaptable material of the lip causes a tight seal to be created between two modules or alternatively between modules and cover strips, effectively preventing moisture and dirt from penetrating.

4

From light bars and safety luminaires to sensors, all TECTON continuous-row luminaires and modules with a higher degree of protection can be securely attached using a new type of **locking mechanism** with integrated sealing plug. Creating the mechanical and electrical connection requires just a single movement, via two levers on the side.

5

In the joint area between the continuous-row modules and trunking, the **foam beads** running along the outer wall of the profile ensure a reliable sealing effect. For extra resistance and UV protection, these are blackened with carbon black. Foam seals inside the profile and translucent sealing strips between the lens elements optimally protect the LED space against unwanted contamination, and thus prevent a further accelerated reduction in luminous flux over the operating time.

6

In the case of interrupted continuous rows, **cover strips** ensure a clean appearance and tight transitions. Laterally running TPE seals and sealing end caps securely seal the joint between the cover strip, rails and light module.

Durable - even in damp environments.

The hot-dip galvanised TECTON trunking has an effective protective layer in which, unlike for traditionally galvanised rails, magnesium and aluminium are added to the zinc bath. It also has a polyester resin-based paint coating. The combination makes TECTON IP64/IP54 extremely corrosion-resistant - and suitable for use in damp environments.

5 connections for power supply (5 x 2.5 mm²)

Separately switchable circuits for extremely easy light control in triple circuit

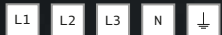

4 poles for two independent emergency lighting circuits (4 x 1.5 mm²)

Two independent emergency lighting circuits allow optimal integration of emergency lighting into general lighting

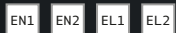

2 control lines with DALI control signal for brightness control (2 x 1.5 mm²)

Efficient, flexible, customised lighting for industrial and commercial buildings



The trunking rail is equipped with a pre-mounted **joint connector**. This enables smooth current tapping over the entire length of the trunking - even in the joint area between two rails. The functionality of the TECTON trunking is not restricted by the sealing sleeve: Luminaires and other lighting modules can also be easily positioned in the IP version.

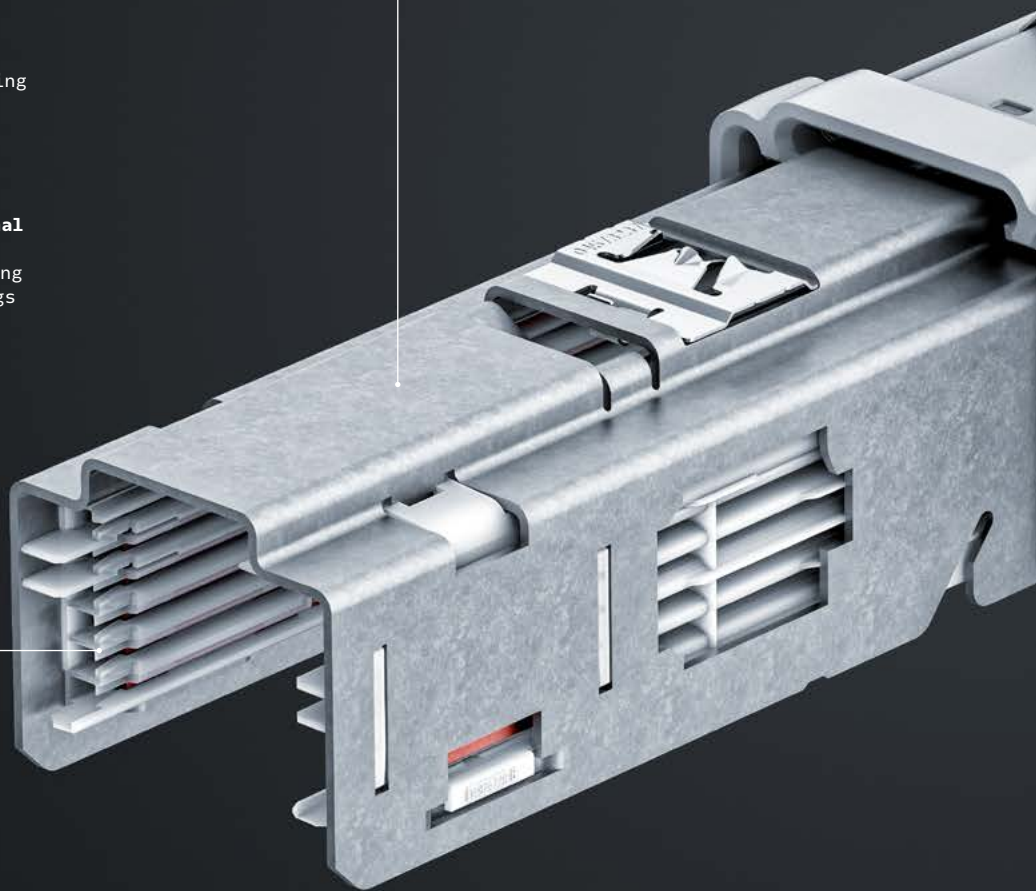

Safe storage for all the technical equipment

An optional cable holder that can be attached to the back of the track offers space to carry additional cable lines. If only one additional cable needs to be accommodated, this can also be carried in the pre-mounted cable duct inside the trunking.

**HERE
TO STAY**

TECTON isn't just a continuous row, it's a continuous-row lighting system. Whether general lighting, safety lighting or lighting management, all modules can be installed on the TECTON trunking according to individual requirements, with 100 % flexibility, and no need for tools, thus saving time. The trunking with an integrated 11-terminal current-conducting section enables the retrofitting of state-of-the-art lighting technologies at any time.



Consistent - even in challenging environments

- Lenses made of impact-resistant and UV-resistant PMMA for maximum protection, even in the oily environments of the metal industry
- For use in projects with permanent ambient temperatures of up to 40 °C
- No halogen or silicones

EXCELLENT LIGHT QUALITY

Long lifetime. Maximum glare control. Carefully selected materials. The TECTON C continuous-row luminaire with split-lens technology combines excellent light output with high resilience. Even in applications where there is more dirt and moisture, users enjoy perfect visual conditions. The extremely high luminous efficacy helps save energy costs and creates the basis for successful environmental building certification. Zumtobel uses environmental product declarations (EPDs) to document the environmental impact of TECTON throughout its entire life cycle, including its CO₂ balance and material composition, for example.

95% luminous efficacy even after 11 years

Even after 100000 operating hours, the equivalent to around 11.4 years of continuous operation, luminous flux and luminous efficacy on the TECTON C HE and HO luminaires fall by only 5% compared with the initial illuminance.

Extra length

With the 2-metre model offering more benefits than the 1.50-metre variant. As around 25% fewer luminaires are required, installation time can be reduced by up to 40% compared with shorter continuous row luminaires.



Perceived glare is minimised

The unique split-lens technology of the TECTON C distributes the light specifically from the centre to the lateral edges. The luminaire therefore appears much less dazzling, the light emission surface more homogeneous.

Another advantage of the split lens is that all common light distribution curves can be created with the same appearance - regardless of whether the lighting is narrow-beam or wide-beam.



The knowledge that everything is running.

Whether LITECOM, emCON, eBox or CPS, monitoring and supply systems play an important role in the operation of an emergency lighting system, enabling every individual TECTON IP54 emergency luminaire to be reliably addressed, configured and tested. Check the status at the touch of a button so that in an emergency all escape routes are well lit and all emergency exits are clearly signposted.

A SAFE WAY OUT

Perfectly coordinated: the continuous sealing concept of the TECTON IP64/IP54 system ensures general lighting, safety lighting and lighting management with splash water and dust protection, all from a single source. Thanks to the TECTON adapter, all modules can be installed without tools and combined as required. Even after commissioning, the continuous-row lighting system remains flexible and can be adapted to new room layouts at any time. If an escape route changes, the safety lighting can also easily be changed.



SAFETY LUMINAIRES

The innovative RESCLITE PRO optics combine high-performance anti-panic, escape-route and property lighting with effective IP protection. The HP (High Performance) version enables luminaire spacing of up to 38 metres, while the HC (High Ceiling) version ensures effective escape-route lighting even in high industrial halls of up to 27 metres in height.

SAFETY SIGN LUMINAIRES

Visible even from a distance: in large factory halls, the CROSSIGN IP54 escape-sign luminaire can be seen even from over 32 metres away, thanks to the optimised lighting technology and a luminance of more than 500 cd/m² in the white spectrum according to DIN 4844.



ecoCALC: calculate savings.

Intelligent control systems also offer a major advantage in the context of renovation projects. Investment in the lighting infrastructure pays for itself even more quickly in the form of significantly reduced operating costs. The calculation tool ecoCALC is a helpful tool for calculating and comparing the cost-effectiveness of lighting solutions in advance. In addition to the investment costs, the tool also considers maintenance costs and CO₂-emissions.

MANAGE LIGHT, SAVE ELECTRICITY

High energy costs, negative CO₂ balance: especially in industries with long operating and production times, energy management is an effective lever for operating successfully in both an economic and environmentally friendly manner. Whether motion and daylight sensors or lighting control systems with pre-defined switch-on times, the intelligent use of lighting management can help reduce power consumption by 20 to 40 %.



MOTION SENSOR

In addition to energy-efficient basic lighting, water- and dust-protected sensors, like the TECTON PST IP54 motion sensor, which only switches on the light when a workplace is actually occupied, can optimise the energy balance even further.



MOTION/DAYLIGHT SENSOR

The combination sensor TECTON MSENS IP54 detects not only motion, it also detects incoming natural daylight and dims or switches the luminaires in the system according to a predefined light level.



LIGHTING MANAGEMENT SYSTEM

Lighting management systems such as LITENET or LITECOM are also used. Via a central building calendar, they make it possible, for example, to predefine switch-on times, and to only switch on lighting when it is actually needed.



Maintenance and repairs by professionals.
Zumtobel's property management package ensures that a lighting solution will provide the best possible service for many years, even under heavy industrial use. A general service level agreement, in which the customer individually determines which services and response times he/she requires, forms the basis of the package.

CRAFT II: a powerhouse for TECTON
High lumen packages in a dust- and splash-water-protected continuous-row lighting system. The CRAFT II offers a powerful, extremely durable high-bay luminaire as an installation variant for the IP64/IP54 version of the TECTON system.

zumtobel.com/craft2

TECTON SERVICE PRODUCTS

From analysis to customer service, from project design to finance, from the Internet of Things to turnkey lighting solutions, Zumtobel supports companies at every stage of their lighting project with tried-and-tested expert knowledge. Services that pay for themselves, especially in a system-based lighting solution such as the TECTON IP64/54. The Zumtobel promise: we ensure you have the best light. You take care of your core business.

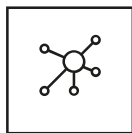

DIGITAL SERVICES

Light is one of the standard services in any room. Zumtobel enables its customers to use lighting infrastructure for digitalisation and to create data-based applications. The data collected with the help of motion detectors or PIR, for example, forms the basis for asset tracking in logistics, or for locating objects or people in a room.



LIGHT AS A SERVICE (LAAS)

Light as a Service allows industrial companies to place light and all the work associated with it in reputable, expert hands. For a monthly light contracting rate instead of a one-off purchase, Zumtobel takes care of all lighting-related activities, from the project design of an efficient lighting system to turnkey delivery and recurring maintenance.

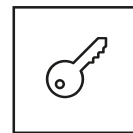

TURNKEY SERVICES

As general contractor and central point of contact, Zumtobel guarantees a turnkey lighting solution based on state-of-the-art technology as well as its international expertise in equipping production and logistics facilities, from project design to commissioning.



Weiler Möbel | AT



Rothoblaas, Kurtatsch | IT

THE RIGHT DEGREE OF PROTECTION FOR EVERY APPLICATION

From IP20 to IP54 and IP64. From dry production halls and warehouses to harsh environments where there is more dust and splash water. TECTON IP64/54 makes the advantages of a tried-and-tested system available for new, challenging industrial applications. Individually configurable. Tool-free installation. 100 % flexible – easy to fit with components. And can be extended at any time to include future technologies. With an IP64 degree of protection for simple light lines. As well as IP54 for the expanded continuous-row lighting system – including general lighting, safety lighting and lighting management.

AS A LIGHT LINE: DUST-PROOF (IP6X)

If only the tracks, general luminaires and cover strips are combined to form a partially or fully equipped light line, the TECTON system is completely dust-tight and meets the requirements of the IP6X degree of protection. According to EN 60598-2-24, the core system can thus also be used in "D-label" environments in which conductive dust may be generated. This applies to metal or carbon processing plants, for example.

AS A CONTINUOUS- ROW LIGHTING SYSTEM: DUST- PROTECTED (IP5X)

If sensors and emergency luminaires are also integrated, the entire TECTON system meets the requirements of the IP5X degree of protection. This means that it is protected against the ingress of dust in damaging quantities. It is also suitable for use in "D-label" applications in which non-conductive dust may deposit, such as in wood, paper or textile processing.

NO CHANCE FOR SPLASH WATER (IPX4)

Whether in refrigerated logistics or in parking garages, with a protection rating of IPX4, the entire TECTON IP64/IP54 portfolio is protected against the ingress of splashing water from all directions (EN 60598-1). Perfect for use in damp environments where luminaires are not exposed to direct water jets.



SAVE TIME AND MONEY WITH TECTON

In a test organised to measure the installation time of different continuous-row systems (with a length of 15 metres), independent refaconsult GmbH found that TECTON can be installed considerably faster than comparable products. TECTON IP64 installation is only by three to four percent slower than our standard IP20 system, and

significantly faster than any of our competition, including systems with lower (IP54) rating! With its reduced complexity and simple installation procedure, TECTON IP remains unchallenged regarding installation speed and simplicity meaning the end user can save meaningful amount of money and time with the TECTON continuous-row system.

15 m continuous-row system

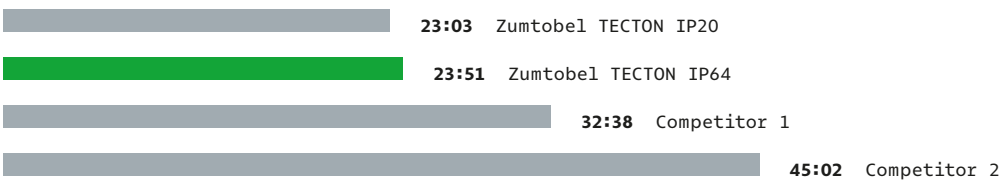
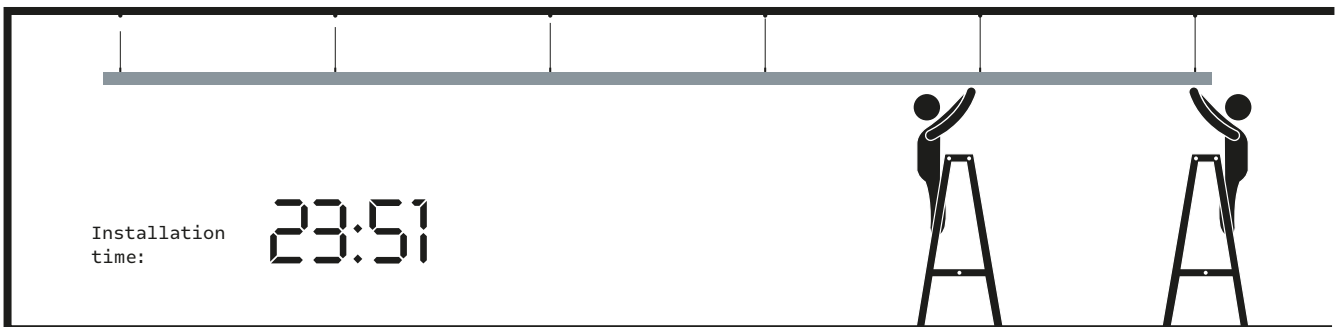



















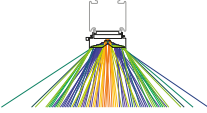
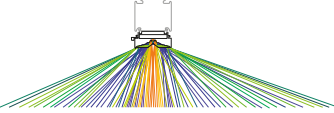

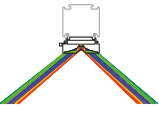

Framework conditions test setup:

Length of continuous-row 15m, ceiling height 7.6m, height of continuous-row 3.35m, 2 persons with ladders. The times refer to assembly including unpacking, but excluding the assembly of the suspensions (approx. 30min).

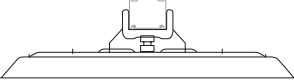
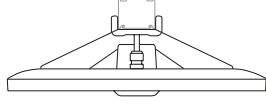
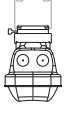

zumtobel.com/tecton_ip

TECTON IP64/IP54

IP64	SUSPENSION	 Ceiling	 Wall	 Chain	 Cord
	TRUNKING	 Electric feed	 Trunking	 Individual trunking	
	CONTINUOUS-ROW LUMINAIRE	 TECTON C			
	Light distribution	 Wide Beam	 Very Wide Beam	 Narrow Beam	
		 Shelf Beam	 Wide Shelf Beam	 Wallwasher	
	ACCESSORIES	 Glare Control mounting optics	 Cable grip	 Strain relief	 Plastic cover
	INDUSTRIAL LUMINAIRES	 CRAFT II performance	 CRAFT II plus	 AMPHIBIA TECTON IP64	
IP54	EMERGENCY LIGHTING	 CROSSIGN	 RESCLITE PRO		
	LIGHTING MANAGEMENT	 PST	 MSENS MC/HC	 bmLINK	 DIMLITE pro

T H E L I G H T

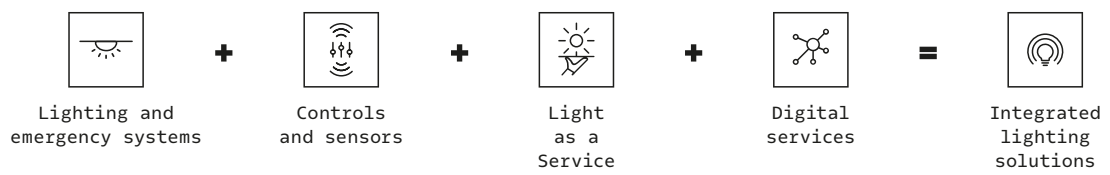

zumtobel.com/contact